



1 ISOMETRIC VIEW
Scale - 1:30

NAME		PRODUCT WEIGHT (kg)	BATCH WEIGHT (kg)		
CONCRETE MIX DESIGN #1		1400	1395		
TABLE OF RAW MATERIAL					
NAME	(D)	QUANTITY	LENGTH (mm)	WEIGHT (kg/m)	WEIGHT (kg)
15M REBAR BEND	15M	2	3033	1.57	4.762

SPECIFICATIONS:

- WEIGHT IS 1,400 kg (3,100 lb);
- DESIGN MIX CODE - BARRIER;
- COMPRESSIVE STRENGTH TO BE 32 Mpa;
- MINIMUM STRIPPING STRENGTH 12- 15MPA;
- DIMENSIONS IN mm U.N.O.

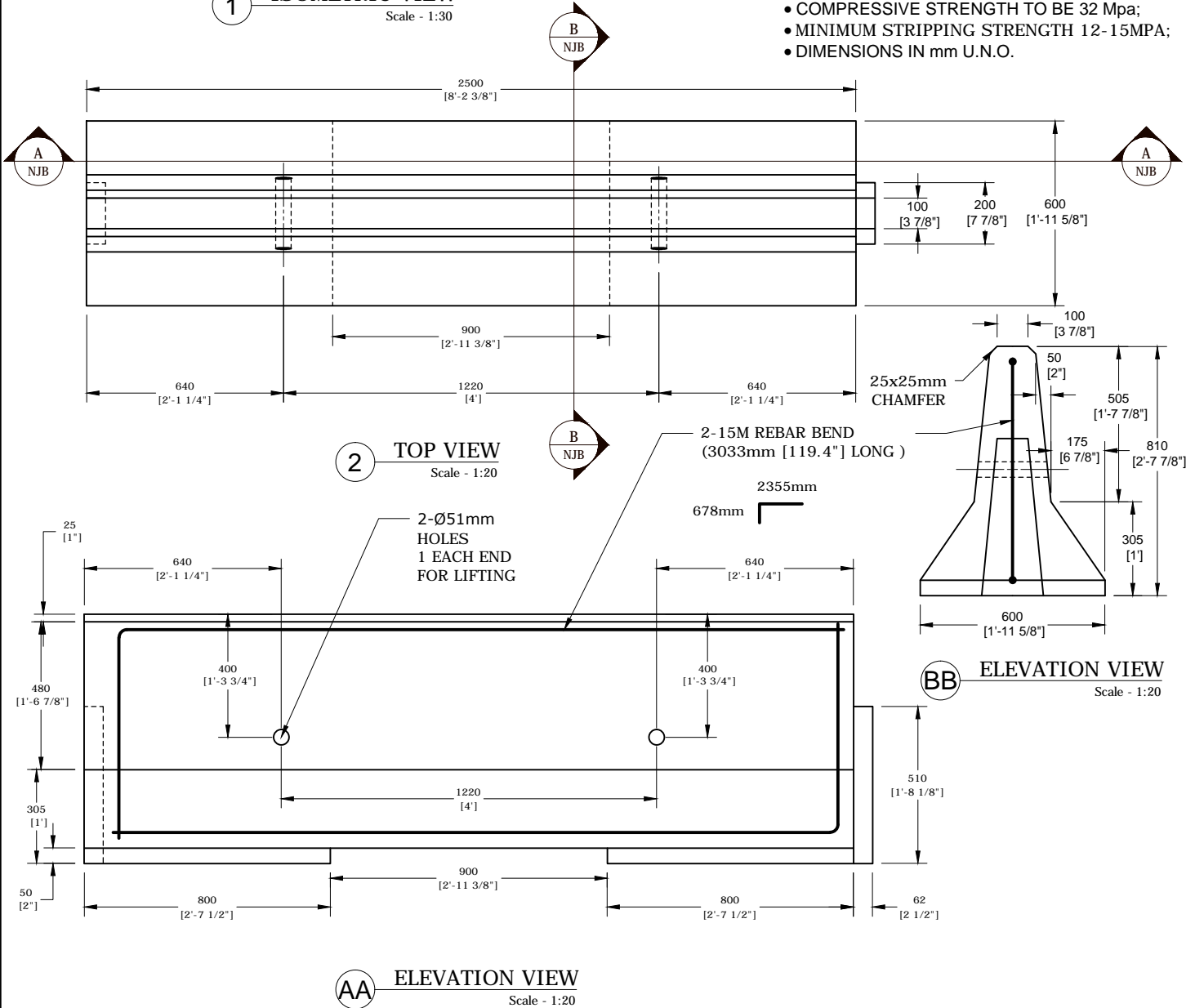

NEW JERSEY BARRIER
STANDARD PRODUCT

April 11, 2013

DRAWN BY: DB

SASKATOON, SK

SCALE - NOTED

DRAWING NUMBER NJB

NO.	REVISION	DATE